

PED 0632

Noise Cancelling Amplified Electret Microphone

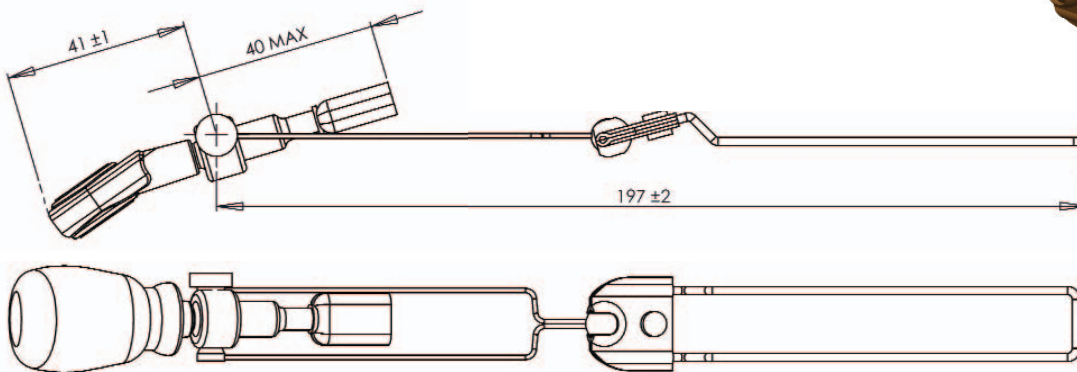

- >25dB noise cancelling at 100Hz
- Aviation microphone equivalent to DC M-7A
- Adjustable rigid wireframe boom including ball and socket bracket
- Same boom and shell as QPL listed mic
- Waterproof to IP67 (sea water resistant)
- Fitted with windsock

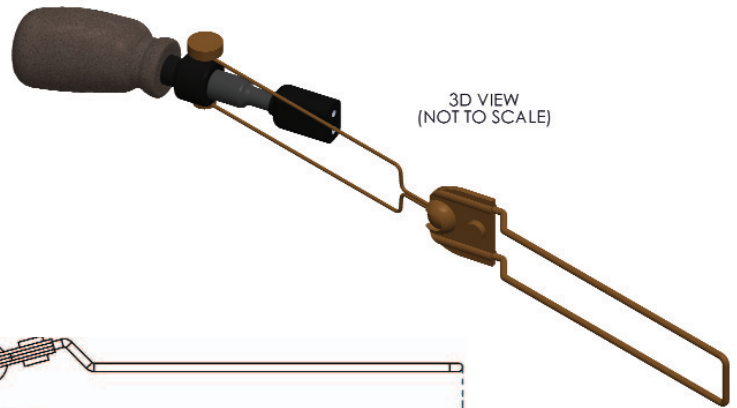

Specification

Sensitivity	-28dBV/Pa ±3 typical at 6mm
Freq response	100Hz to 10kHz
Distortion	<5% at +20dB
Terminals	Wire ended, not polarity sensitive
Power	8-16V via 470Ω
Load impedance	150Ω
High temp	70°C/55°C (Store/op)
Low temp	-40°C/-20°C (Store/op)
Humidity	95% at 65°C
Water	Section 10 Category Y RTCA DO-160E
Salt fog	Section 14 category S RTCA DO-160E
Shock drop	Section 7 category A RTCA DO-160E
Fungus	Section 13 RTCA DO-160E
Dust	Method 510.5 Mil Std 810

Typical polar response at 1kHz/1m

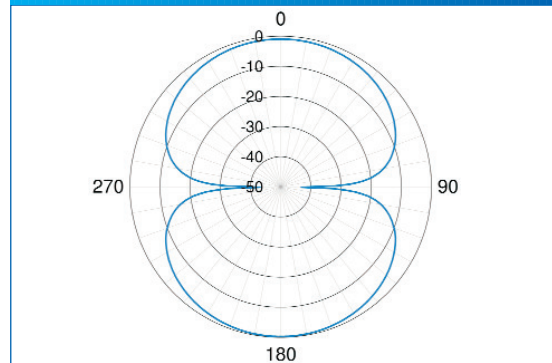

Typical near and far field frequency response

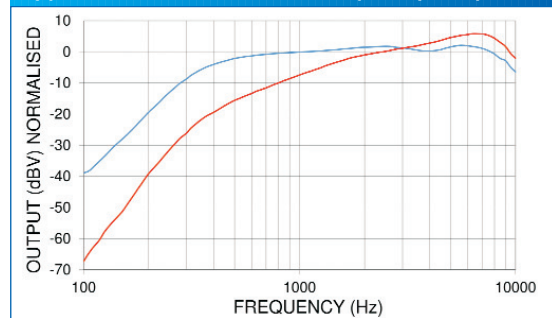

Tel 01202 624910 Fax 01202 632452 Email sales@pambry.co.uk

www.pambry.co.uk

