

## Compact Headset Tester

- Part No: CHT\*\*\*\*
- Subjectively test Headphones, Headsets with boom microphones, Communication Helmets with boom or mask microphones & PTT switches
- Simple indicator system for DC continuity
- Single fully integrated unit
- Accepts Electret, Dynamic or Amplified type microphones
- Battery powered
- Tailored to customers headset (see table below)
- Straightforward layout, easy to use



### Characteristics

Dimensions: 82mm x 130mm x 48mm

Weight: 320gm

Microphone: Dynamic 5ohm to 1000ohm

Electret 8vDC/10Kohm

Amplified 8vDC/150ohm

Earphone: 25-1000 Ohms

Input Levels: 300µV to 30mV

Output Levels: 2V max

### How to order

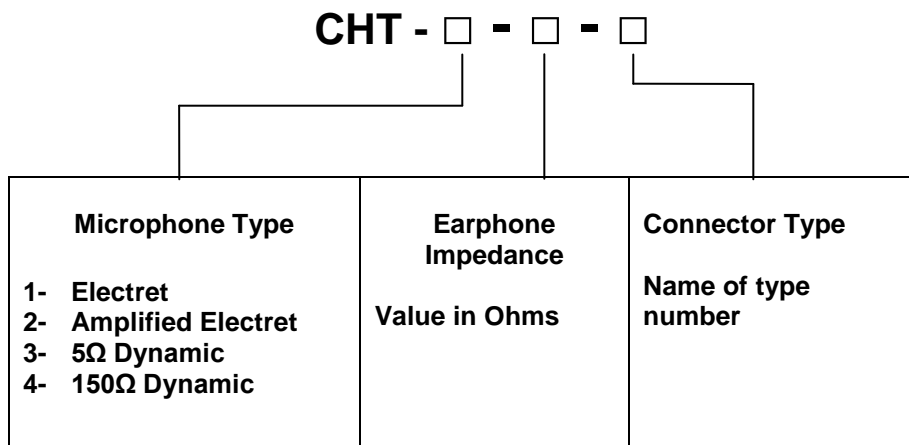

### Contact Pambry Electronics at

Pambry Electronics Limited, Units 7 & 8 Ventura Centre, Ventura Place, Upton Industrial Estate  
Upton, Poole, Dorset BH16 5SW, United Kingdom

By telephone +44 (0)1202 624910 By fax +44 (0)1202 632452